

Owner's Manual

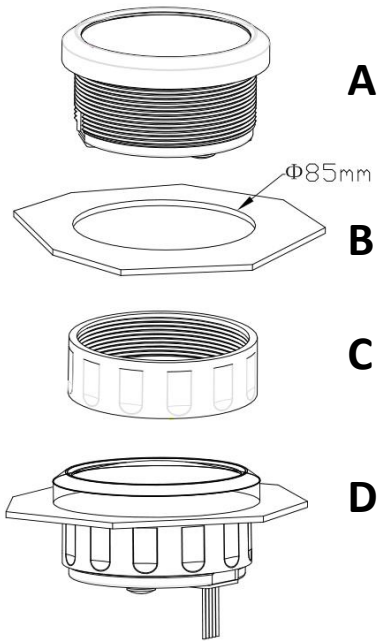

Picture B: Before installation, firstly, to open a hole $\Phi 85\text{mm}$ (3 3/8") of the panel, make sure there is a space with (55mm backyard of panel) as well.

Picture D: Put the gauge in the hole and screw down.



GPS antenna



Default trip is for single accumulative, will not be cleared after power off

Accumulated mileage, not cleared after power off

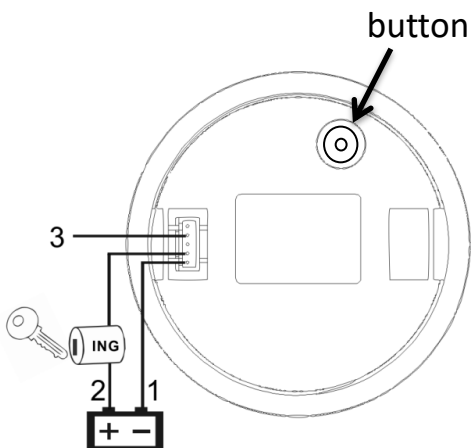

Connection

- 1 Black: Ground(-)
- 2 Red: 9-32VDC
- 3 Yellow: Backlight

1. Turn it on, then the meter starts to search for the signal and LCD will display "COG", if there is still no GPS signal after three minutes, LCD displays "Err".
2. Shortly press the button to change the backlight color: Backlight changed in sequence: red (default) → green → blue → white → yellow → cyan → Purple → (automatic). Automatic: Automatically switch the backlight color every 1 minute, Cycle switch according to the above sequence.
3. Keep on pressing the rubber button of the backside for 5 seconds, Single mileage can be cleared.