

Picture B: Before installation, firstly, to open a hole $\Phi 80-82\text{mm}$ (3-1/5") of the panel, make sure there is a space with (55mm backyard of panel) as well.

Picture D: Put the gauge in the hole and screw down.

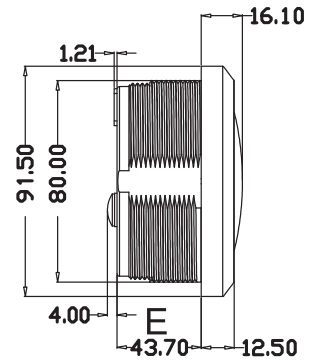

Picture E: Size and annotations

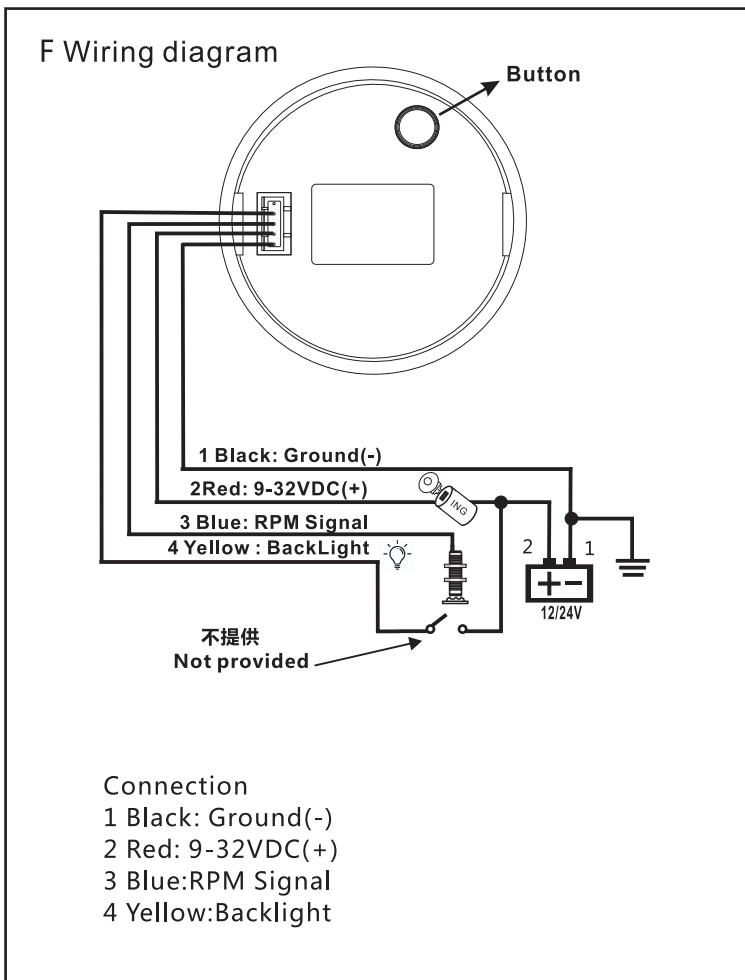

Diesel Engine	
Gear Number	Speed Ratio
Speed Ratio = Gear Number	

Outboard	
Poles	Speed Ratio
4	2
6	3
8	4
10	5
12	6

Inboard Gas Engine		
Cylinder	Cycle	Speed Ratio
4	4	2
6	4	3
8	4	4
10	4	5
12	4	6

Technical parameters:
 Operating voltage: 9~32VDC
 Operating current: $\leq 100\text{mA}$
 Operating temperature: $-30\sim 80^{\circ}\text{C}$
 Storage temperature: $-40\sim 85^{\circ}\text{C}$

1. Keep on pressing the rubber button of the backside for 3 seconds, and then enter into setting mode, if leave button more than 3 seconds, it will be out of setting mode.
2. The value will increase when you press the button. When you leave the button and then press it again, the value will decrease. Ten longer you press the button, the quicker the value will count up. The minimum step value is 0.1 and the adjustable range is 1.0~360.
3. When you get the required speed ratio value after adjustment, please leave the button. The tachometer automatically saves the result you set after 3 seconds, If the setup doesn't meet your demand, please re-setup.
4. Short press the button to change the backlight color: Backlight changed in sequence: red (default) \rightarrow green \rightarrow blue \rightarrow white \rightarrow yellow \rightarrow cyan \rightarrow Purple \rightarrow (automatic). Automatic: Automatically switch the backlight color every 1 minute, Cycle switch according to the above sequence.