

Before installation, firstly, to open a hole $\Phi 85\text{mm}$ of the panel, make sure there is a space with (55mm backyard of panel) as well.

在仪表安装板上开一个直径为85mm的孔并确保仪表板后面至少要有55mm的空间。

Put the gauge in the hole and screw down.

将仪表装入开好的孔中 调整好位置后将后盖圈拧紧。

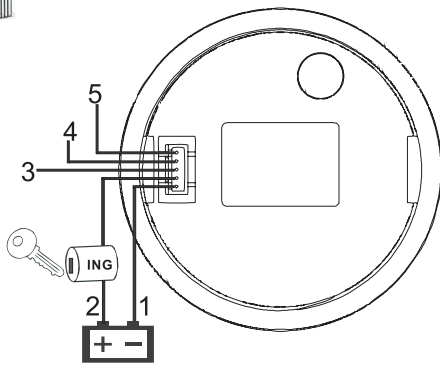

接线方式

- 1 黑色线：电源负极 (-)
- 2 红色线：9~32VDC
- 3 蓝色线：RPM信号
- 4 黄色线：水温/油温信号
- 5 白色线：油压信号

Connection

- 1 Black : Ground (-)
- 2 Red : 9~32VDC(+)
- 3 Blue : RPM signal
- 4 Yellow : Temperature signal
- 5 White : Oil pressure signal

1. 按住仪表背后的橡胶按钮3秒钟，进入设置模式。如果松开按钮大于3秒钟，将退出设置模式。
2. 安住按钮，数值一直递增；松开按钮再按住按钮，数值一直递减。计数最小步进值0.1，可调范围1.0-360。
3. 调整到符合您的要求速比值后，请松开按钮。3秒后转速表自动保存您设置的结果。如果设置不符合您的要求，请重新设置。
4. 必须先按下按键再上电，可以切换中英文显示。

1. Keep on pressing the rubber button of the backside for 3 seconds, and then enter into setting mode, if leave button more than 3 seconds, it will be out of setting mode.
2. The value will increase when you press the button. When you leave the button and then press it again, the value will decrease. The minimum step value is 0.1 and the adjustable range is 1~360.
3. When you get the required speed ratio value after adjustment, please leave the button. The tachometers will autoclave your setup after 3 seconds. If the setup doesn't meet your demand, please re-setup.
4. Must press the button first and power up, can select English or Chinese.